



ATENDI

| protech led



LED STRIP SPECIFICATION

AT-RGBW60-DMX-1





AT-RGBW60-DMX-1

DESCRIPTION

DMX512 RGBW LED strip lights let you create millions of colors by just mixing red, green, and blue colors. With the ability to control each individual pixel and each individual channel, the color mix and color effects possibilities are endless.



- Compatible with DMX512(1990) protocol.
- Adopting RS485 signal trunk and signal differential transmission mode to ensure stronger ability of anti-interference and longer transmission distance
- Auto matically addressing with editor

DIMENSIONS & WATERPROOF

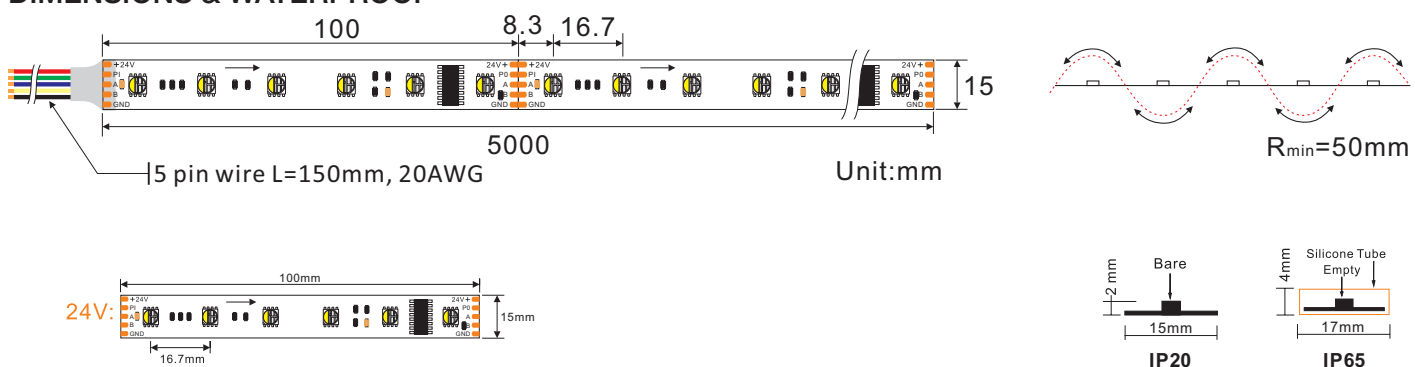

PRODUCT SPECIFICATION

Dimension	5000x15x2mm	Voltage (V)	DC24V
Chip Type	5050SMD	Current (A/m)	0.8A
Chip Density	60 LEDs/m	Power (W/m)	19.2W(4 colors 100% on)
Step LEDs	6 LEDs	Beam Angle	120°
Step Length	100mm	Operation Temperature	-20°C~50°C

PRODUCT PHOTOMETRICS- WHITE DIODES ONLY (DATA BASE ON IP20)

CCT (K)	Lumen (lm/m)	Power (w/m)	Efficacy (lm/w)	CRI	R9
2700±100	489.22	4.8	101.92	73.36	3.65
3000±100	479.33	4.8	99.86	77.62	8.78
4000±200	508.66	4.8	105.97	79.86	17.98
6000±300	517.68	4.8	107.85	78.42	18.63



AT-RGBW60-DMX-1

PRODUCT PHOTOMETRICS - RED, GREEN AND BLUE DIODES (DATA BASE ON IP20)

Color	Peak Wavelength (nm)	Dominant Wavelength (nm)	Lumen (lm/m)	Power (w/m)	Efficacy (lm/w)
RED	630	620	141.89	4.26	33.33
GREEN	518	527	441.42	5.37	82.21
BLUE	465	469	122.97	4.77	25.76

PRODUCT PHOTOMETRICS - ALL FOUR COLOR AT 100% ON (DATA BASE ON IP20 CRI>90)

CCT (K)	Lumen (lm/m)	Power (w/m)	Efficacy (lm/w)	CRI	R9
RGB+2700	1113.22	19.2	57.98	55.35	-
RGB+3000	1131.26	19.2	58.92	58.55	-
RGB+4000	1207.49	19.2	62.89	62.78	-
RGB+6000	1226.11	19.2	63.86	70.61	-

WIRING DIAGRAM

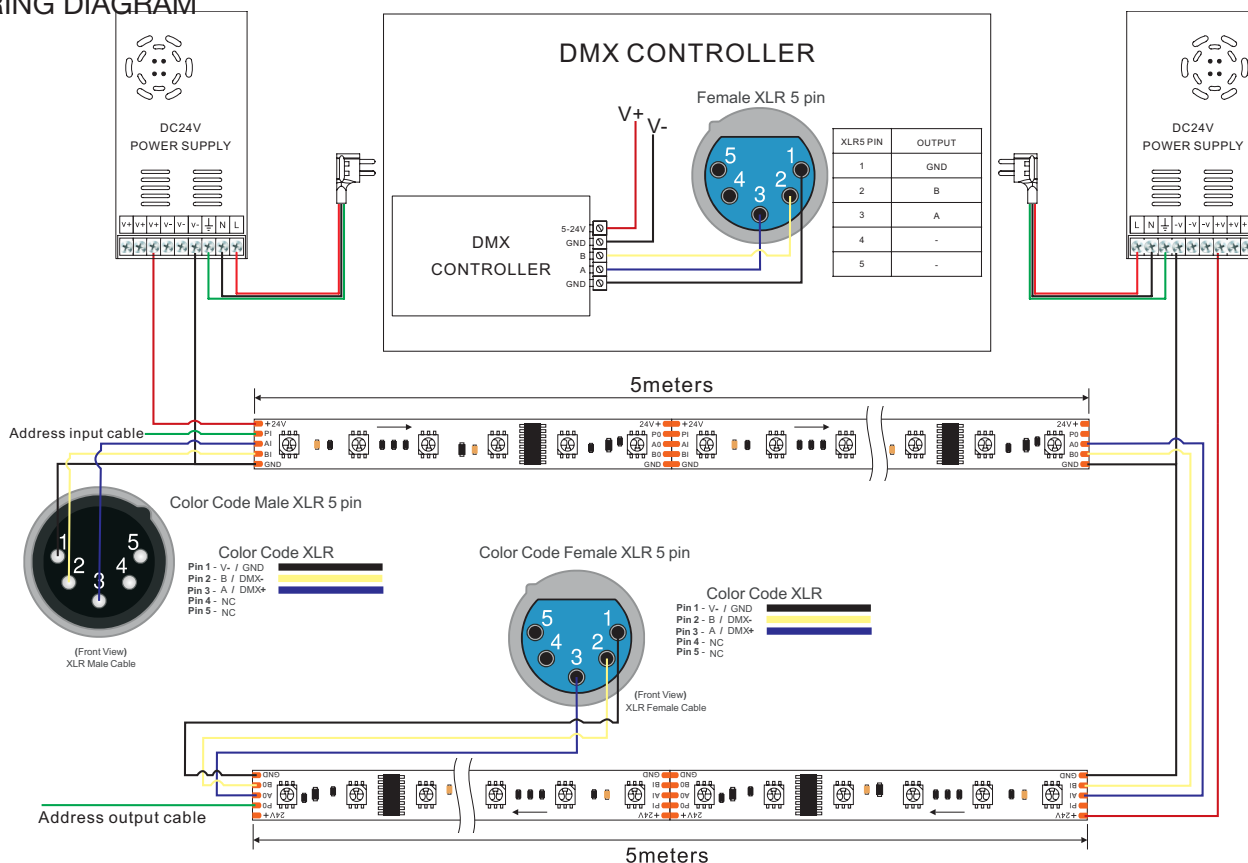



AT-RGBW60-DMX-1

WIRING DIAGRAM

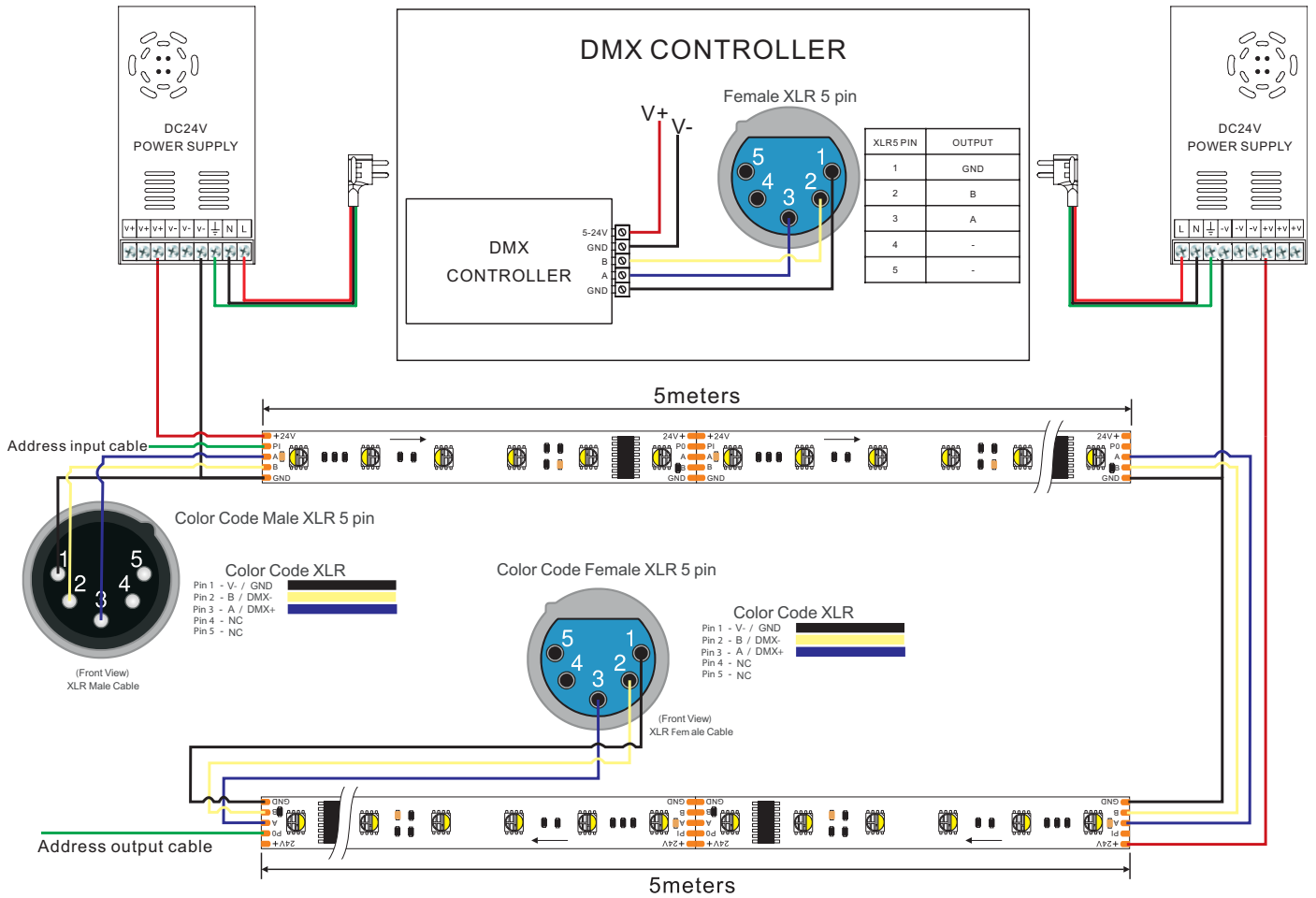

Important:

1. Regular DMX512 LED Strip not include the XLR connector, if need XLR connector, extra cost will be added.
2. If you want to change the starting address, you will need a DMX Address Editor, available on our website.